

Absolute encoders - singleturn

Standard optical	5850 / 5870 (shaft / hollow shaft)	Parallel / analog
-------------------------	---	--------------------------



The singleturn encoders 5850 and 5870 with parallel or analog interface and optical sensor technology feature a refresh rate of the position data of 1.6 kHz.

With the parallel output a resolution of max. 14 bit can be achieved – with the analog output the 4 ... 20 mA signals can achieve a resolution of 13 bits.



High rotational speed	Temperature range -20°...+85°C	High protection level IP	High shaft load capacity	Shock / vibration resistant	Magnetic field proof	Optical sensor

Adaptable

- Power supply 5 V DC or 10 ... 30 V DC.
- Cable or connector.
- Gray code, binary code or BCD code.

Robust

- High shock resistance.
- Temperature range from -20°C up to +85°C.
- Protection rating up to max. IP66.

Absolute encoders singleturn

Order code	8.5850	.	X	X	X	X	.	X	X	X
Shaft version	Type		a	b	c	d		e	f	

<p>a Flange</p> <p>1 = clamping flange, ø 58 mm [2.28"]</p> <p>2 = synchro flange, ø 58 mm [2.28"]</p> <p>b Shaft (ø x L), with flat</p> <p>1 = 6 x 10 mm [0.24 x 0.39"]</p> <p>2 = 10 x 20 mm [0.39 x 0.79"]</p>	<p>c Interface / power supply</p> <p>3 = parallel / 5 V DC</p> <p>4 = parallel / 10 ... 30 V DC</p> <p>7 = 4 ... 20 mA / 5 V DC</p> <p>8 = 4 ... 20 mA / 10 ... 30 V DC</p> <p>d Type of connection</p> <p>1 = axial cable, 1 m [3.28'] PVC</p> <p>2 = radial cable, 1 m [3.28'] PVC</p> <p>3 = axial M23 connector, without mating connector</p> <p>5 = radial M23 connector, without mating connector</p>	<p>e Code type and division</p> <p>G13 = 13 bit (for interface 7 and 8, 4 ... 20 mA) see table 1 (for interface 3 and 4, parallel)</p> <p>f Options</p> <p>2 = SET ¹⁾ and V/R</p> <p>3 = SET and Latch ¹⁾</p> <p>4 = V/R ¹⁾ and Latch</p>
---	---	--

Order code	8.5870	.	X	X	X	X	.	X	X	X
Hollow shaft	Type		a	b	c	d		e	f	

<p>a Flange</p> <p>1 = hollow shaft with spring element, short</p> <p>2 = blind hollow shaft with spring element, short</p> <p>3 = hollow shaft with stator coupling, ø 65 mm [2.56"]</p> <p>4 = blind hollow shaft with stator coupling, ø 65 mm [2.56"]</p> <p>b Hollow shaft (insertion depth blind hollow shaft with flange 2 and 4 max. 30 mm [1.18"])</p> <p>6 = ø 10 mm [0.39"]</p> <p>8 = ø 12 mm [0.47"]</p>	<p>c Interface / power supply</p> <p>3 = parallel / 5 V DC</p> <p>4 = parallel / 10 ... 30 V DC</p> <p>d Type of connection</p> <p>1 = radial cable, 1 m [3.28'] PVC</p> <p>2 = radial M23 connector, without mating connector</p>	<p>e Code type and division</p> <p>see table 1 (for interface 3 and 4, parallel)</p> <p>f Options</p> <p>2 = SET ¹⁾ and V/R</p> <p>3 = SET and Latch ¹⁾</p> <p>4 = V/R ¹⁾ and Latch</p>
---	--	--

1) For parallel version, 14 bit and 17-pin connector.

Absolute encoders - singleturn

Standard optical	5850 / 5870 (shaft / hollow shaft)	Parallel / analog
-------------------------	---	--------------------------

Table 1: Code type and divisions for encoders with parallel output										Interface and power supply, version 3 or 4 (parallel)										
Division	250	360	500	720	900	1000	1024 10 bit	1250	1440	1800	2000	2500	2880	3600	4000	4096 12 bit	5000	7200	8192 13 bit	16384 14 bit
Order code Gray/Gray-Excess	E02	E03	E05	E07	E09	E01	G10	E12	E14	E18	E20	E25	E28	E36	E40	G12	E50	E72	G13	G14
Order code Binary	B02	B03	B05	B07	B09	B01	B10	BA2	BA1	B18	B20	B25	B28	B36	B40	B12	B50	B72	B13	B14
Order code BCD	D02	D03	D05	D07	D09	D01	D10	DA2	DA1	D18	D20									

Mounting accessory for shaft encoders	Order no.
---------------------------------------	-----------

Coupling	bellows coupling ø 19 mm [0.75"] for shaft 6 mm [0.24"]	8.0000.1102.0606
	bellows coupling ø 19 mm [0.75"] for shaft 10 mm [0.39"]	8.0000.1102.1010

Mounting accessory for hollow shaft encoders	Dimensions in mm [inch]	Order no.
--	-------------------------	-----------

Cylindrical pin, long	with fixing thread	8.0010.4700.0000
------------------------------	--------------------	-------------------------

for flange with spring element
(flange type 1 + 2)

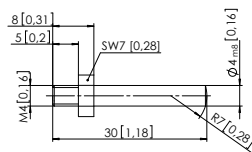

Connection technology	Order no.
-----------------------	-----------

Cordset, pre-assembled	M23 female connector with coupling nut for analog interface, 12-pin 2 m [6.56'] PVC cable	8.0000.6901.0002.0031
	M23 female connector with coupling nut, for parallel interface, 17-pin 2 m [6.56'] PVC cable	8.0000.6741.0002

Connector, self-assembly (straight)	M23 female connector with coupling nut for analog interface, 12-pin	8.0000.5012.0000
	M23 female connector with coupling nut for parallel interface, 17-pin	8.0000.5042.0000

Further accessories can be found in the accessories section or in the accessories area of our website at: www.kuebler.com/accessories.
Additional connectors can be found in the connection technology section or in the connection technology area of our website at: www.kuebler.com/connection_technology.

Technical data

Mechanical characteristics	
Maximum speed	shaft version 12000 min ⁻¹ hollow shaft version 6000 min ⁻¹ 1)
Mass moment of inertia	shaft version approx. 1.8 x 10 ⁻⁶ kgm ² hollow shaft version approx. 6 x 10 ⁻⁶ kgm ²
Starting torque at 20°C [68°F]	shaft version < 0.01 Nm hollow shaft version < 0.05 Nm
Load capacity of shaft	radial 80 N axial 40 N
Weight	approx. 0.4 kg [14.11 oz]

Protection acc. to EN 60529	shaft version IP65 hollow shaft version IP66
Working temperature range	-20°C ... +85°C 2) 3) [-4°F ... +185°F] 2) 3)
Material	shaft / hollow shaft stainless steel
Shock resistance acc. EN 60068-2-27	2500 m/s ² , 6 ms
Vibration resistance acc. EN 60068-2-6	100 m/s ² , 10 ... 2000 Hz

1) For continuous operation max. 1500 min⁻¹.
2) 80°C [176°F] for shaft version and cable connection.
3) 70°C [158°F] for hollow shaft version and cable connection.

Absolute encoders - singleturn

Standard optical	5850 / 5870 (shaft / hollow shaft)	Parallel / analog
-------------------------	---	--------------------------

Electrical characteristics parallel interface		
Power supply (+V)	5 V DC (±5 %)	10 ... 30 V DC
Output driver	Push-pull	Push-pull
Power consumption (no load)	typ. 109 mA	109 mA
	max. 169 mA	169 mA
Permissible load / channel	max. +/- 10 mA	max. +/- 10 mA
Refresh rate of the position data	1600/s	1600/s
Signal level	HIGH	min. 3.4 V
	LOW (I _{Load} = 10 mA)	max. 1.5 V
	LOW (I _{Load} = 1 mA)	max. 0.3 V
Rising edge time t_r (without cable)		max. 0.2 μs
		max. 1 μs
Falling edge time t_f (without cable)		max. 0.2 μs
		max. 1 μs
Short circuit proof outputs	no	no
Reverse polarity protection of the power supply	no	yes
UL approval	file 224618	
CE compliant acc. to	EMC guideline 2014/30/EU RoHS guideline 2011/65/EU	

Electrical characteristics voltage interface 4 ... 20 mA		
(only shaft version)		
Sensor		
Interface type	4 ... 20 mA	4 ... 20 mA
Power supply (+V)	10 ... 30 V DC	5 V DC
Power consumption (no load)	typ. 70 mA	70 mA
	max. 84 mA	84 mA
Current loop		
Power supply (+V)	10 ... 30 V DC	
Analog signal	4 ... 20 mA	
Max. input resistance of the input circuit	200 Ohm (U _s = 10 V), 1 kOhm (U _s = 30 V)	
Measuring range	0 ... 360°	
Max. error, 25°C [77°F]	0.2°	
Resolution	13 bit	
Setting time	max. 2 ms	
Temperature coefficient	0.1°/10 K	
Current with scan error	≤ 3.5 mA	
Sensor component and current loop are galvanically isolated		
UL-certified	file 224618	
CE compliant acc. to	EMC guideline 2014/30/EU RoHS guideline 2011/65/EU	

Absolute encoders singleturn

Control inputs

Switching levels of the control inputs

Power supply	5 V DC	10 ... 30 V DC
Switching level	LOW	≤ 1.7 V
	HIGH	≥ 3.4 V

Up/Down input to switch the counting direction

As a standard, absolute encoders deliver increasing code values when the shaft rotates clockwise (cw), when looking from the shaft side. When the shaft rotates counter-clockwise (ccw), the output delivers accordingly decreasing code values. The same applies to models with current interfaces. When the shaft rotates clockwise, the output delivers increasing current values, and decreasing values when it rotates counter-clockwise. As long as the Up/Down input receives the corresponding signal (HIGH), this feature is reversed. Clockwise rotation will deliver decreasing code/current values while counter-clockwise rotation will deliver increasing code/current values.

The response time is: for 5 V DC power supply, 0.4 ms
for 10 ... 30 V DC power supply, 2 ms

SET input

This input is used to reset (zero) the encoder. A control pulse (HIGH) sent to this input allows the current position value to be saved as the new zero position in the encoder.

For models equipped with a current interface, the analog output (4 ... 20 mA) will be set accordingly to the value 4 mA.

Note : After applying power to the encoder and before activating the SET input, a count direction (cw or ccw) must be clearly defined on the Up/Down input!

The response time is: for 5 V DC power supply, 0.4 ms
for 10 ... 30 V DC power supply, 2 ms

LATCH input

This input is used to "freeze" the current position value. The position value will be statically available on the parallel output as long as this input remains active (HIGH).

The response time is: for 5 V DC power supply, 140 μs,
for 10 ... 30 V DC power supply, 200 μs

Absolute encoders - singleturn

Standard optical	5850 / 5870 (shaft / hollow shaft)	Parallel / analog
-------------------------	---	--------------------------

Terminal assignment

max. 13 bit, max. 2 options

Interface	Type of connection	Cable (isolate unused wires individually before initial start-up)																		
		Signal	0 V	+V	1	2	3	4	5	6	7	8	9	10	11	12	13	ST/VR	VR/LH	⊥
3, 4 (parallel)	5850: 1, 2																			
	5870: 1	Cable color:	WH	BN	GN	YE	GY	PK	BU	RD	BK	VT	GY	RD	WH	BN	WH	YE	WH	

14 bit, max. 2 options

Interface	Type of connection	Cable (isolate unused wires individually before initial start-up)																			
		Signal	0 V	+V	1	2	3	4	5	6	7	8	9	10	11	12	13	ST/VR	VR/LH	14	⊥
3, 4 (parallel)	5850: 1, 2																				
	5870: 1	Cable color:	WH	BN	GN	YE	GY	PK	BU	RD	BK	VT	GY	RD	WH	BN	WH	YE	WH	GY	BN

max. 13 bit, max. 2 options

Interface	Type of connection	M23 connector, 17-pin																			
		Signal	0 V	+V	1	2	3	4	5	6	7	8	9	10	11	12	13	ST/VR	VR/LH	⊥	
3, 4 (parallel)	5850: 3, 5																				
	5870: 2	Pin:	1	2	3	4	5	6	7	8	9	10	11	12	13	14	15	16	17		

14 bit, max. 1 option

Interface	Type of connection	M23 connector, 17-pin																			
		Signal	0 V	+V	1	2	3	4	5	6	7	8	9	10	11	12	13	ST/VR	VR/LH	14	⊥
3, 4 (parallel)	5850: 3, 5																				
	5870: 2	Pin:	1	2	3	4	5	6	7	8	9	10	11	12	13	14	15	16	17		

13 bit

Interface	Type of connection	Cable (isolate unused wires individually before initial start-up)																			
		Signal	0 V	+V	-	-	+I	-I	ST	VR											
7, 8 (4 ... 20 mA)	5850: 1, 2																				
		Cable color:	WH	BN	GN	YE	GY	PK	BU	RD	BK	VT	GY	PK	RD	BU					

13 bit

Interface	Type of connection	M23 connector, 12-pin															
		Signal	0 V	+V	-	-	+I	-I	ST	VR					⊥		
7, 8 (4 ... 20 mA)	5850: 3, 5																
		Pin:	1	2	3	4	5	6	7	8	9	10	11	12	PH		

- +V: Encoder power supply +V DC
- 0 V: Encoder power supply ground GND (0 V)
- Sig.: 1 =MSB; 2 = MSB-1; 3 = MSB-2 etc.
- ST: SET input
- Parallel: The current position value is stored as new zero position.
- 4 ... 20 mA: measured value set to 4 mA
- VR: Up/down input. As long as this input is active, decreasing code values are transmitted when shaft turning
- +I: Current loop input
- I: Current loop output
- LH: LATCH input. Active HIGH. The current position is saved and is statically available at the output.
- PH ⊥: Plug connector housing (shield)

Top view of mating side, male contact base:

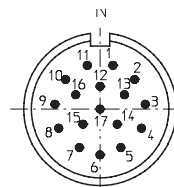

M23 connector, 17-pin (parallel)

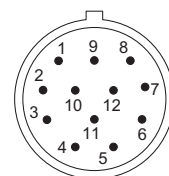

M12 connector, 12-pin (4 ... 20 mA)

Absolute encoders - singleturn

Standard optical	5850 / 5870 (shaft / hollow shaft)	Parallel / analog
-------------------------	---	--------------------------

Dimensions shaft version

Dimensions in mm [inch]

Clamping flange, \varnothing 58 [2.28]
with shaft, \varnothing 10 [0.39]
Flange type 1

1 3 x M3, 5 [0.20] deep

D	Fit	L
6 [0.24]	h8	10 [0.39]
10 [0.39]	f7	20 [0.79]

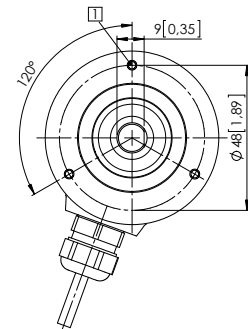
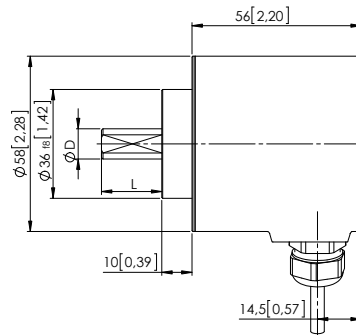

Synchro flange, \varnothing 58 [2.28]
with shaft, \varnothing 6 [0.24]
Flange type 2

1 3 x M4, 10 [0.39] deep

D	Fit	L
6 [0.24]	h8	10 [0.39]
10 [0.39]	f7	20 [0.79]

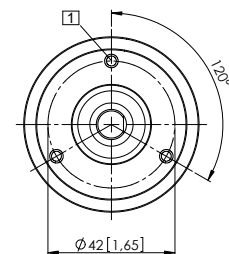
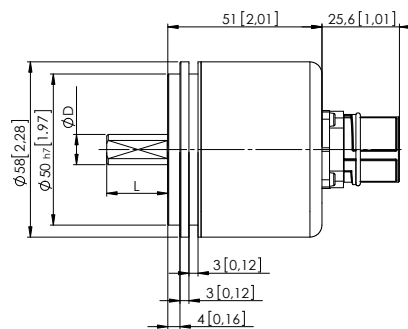

Dimensions hollow shaft version

Dimensions in mm [inch]

Flange with spring element, short
Flange type 1 and 2

- 1 3 x M3, 5 [0.20] deep
- 2 Recommended torque for the clamping ring 0.6 Nm

D	Fit
10 [0.39]	H7
12 [0.47]	H7

Insertion depth blind hollow shaft with flange 2:
max. 30 mm [1.18"]

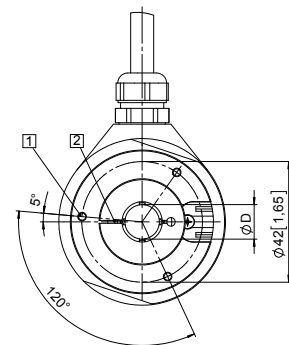
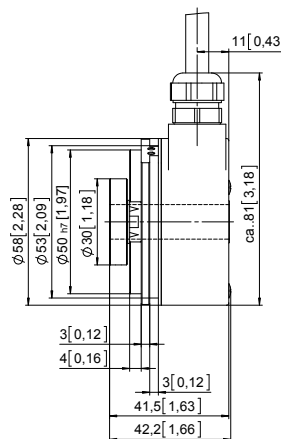

Flange with stator coupling, \varnothing 65 [2.56]
Flange type 3 and 4

- 1 Recommended torque for the clamping ring 0.6 Nm

D	Fit
10 [0.39]	H7
12 [0.47]	H7

Insertion depth blind hollow shaft with flange 4:
max. 30 mm [1.18"]

