

# Absolute encoders – multiturn

<b>Standard, ATEX/IECEX – zone 1/21 SIL2/PLd, mechanical multiturn, optical</b>	<b>Sendix 7063FS2 / 7083FS2 (shaft / hollow shaft)</b>	<b>SSI/BiSS + SinCos</b>
---	--	--------------------------



**SIL2**  
Functional Safety  
**PLd**

**Ex protection and Functional Safety in one device.**

The absolute multiturn encoders 7063FS2 and 7083FS2 of the Sendix family are suited for use in safety-related applications up to SIL2 acc. to EN 61800-5-2 or PLd to EN ISO 13849-1.

In addition, these devices ensure Ex protection in a compact 70 mm housing out of seawater durable aluminum.



## Functional Safety

- Encoder with individual certificate from TÜV.
- Suitable for applications up to SIL2 acc. to EN 61800-5-2.
- Suitable for applications up to PLd acc. to EN ISO 13849-1.
- SSI or BiSS interface with incremental SinCos tracks with 2048 ppr.
- Certified mechanical mounting + electronic.

## Explosion protection

- “Flameproof-enclosure” version.
- ATEX with EC type examination certificate.
- IECEx with certificate of conformity (CoC).

**Order code**      **8.7063FS2 . 1 X 4 X . X X 2 1 . XXXX**

**Shaft version**      Type      a b c d e f g h i <sup>1)</sup>

**a Flange**  
1 = clamping / synchronous flange, IP67, ø 70 mm [2.76"]

**b Shaft (ø x L)**  
2 = 10 x 20 mm [0.39 x 0.79"], with flat  
1 = 12 x 25 mm [0.47 x 0.98"],  
with keyway for 4 x 4 mm [0.16 x 0.16"] key

**c Interface / power supply**  
4 = SSI, BiSS + 2048 ppr. SinCos / 10 ... 30 V DC

**d Type of connection**  
1 = axial cable, 2 m [6.56'] PUR  
2 = radial cable, 2 m [6.56'] PUR  
A = axial cable, length > 2 m [6.56']  
B = radial cable, length > 2 m [6.56']  
preferred length see **i**, e. g.: 0100 = 10 m [32.81']

**e Code**  
B = SSI, binary  
C = BiSS, binary  
G = SSI, gray

**f Resolution <sup>2)</sup>**  
A = 10 bit ST + 12 bit MT  
1 = 11 bit ST + 12 bit MT  
2 = 12 bit ST + 12 bit MT  
3 = 13 bit ST + 12 bit MT  
4 = 14 bit ST + 12 bit MT  
7 = 17 bit ST + 12 bit MT

**g Inputs / outputs <sup>2)</sup>**  
2 = SET input

**h Options**  
1 = no option

**i Cable length in dm <sup>1)</sup>**  
0050 = 5 m [16.40']  
0100 = 10 m [32.81']  
0150 = 15 m [49.21']  
0200 = 20 m [65.62']

*Optional on request*  
- special cable length  
- other singleturn resolutions  
- seawater resistant (stainless steel V4A)

1) Not applicable with connection types 1 and 2.  
2) Resolution, preset value and counting direction factory-programmable.

# Absolute encoders – multiturn

**Standard, ATEX/IECEX – zone 1/21  
SIL2/PLd, mechanical multiturn, optical**

**Sendix 7063FS2 / 7083FS2 (shaft / hollow shaft)**

**SSI/BiSS + SinCos**

**Order code  
Hollow shaft**

**8.7083FS2** . **XX2X** . **XX21** . **XXXX**  
Type **a b c d e f g h i** <sup>1)</sup>

**a Flange**

- 1 = with spring element, short
- 5 = with stator coupling, IP67, ø 65 mm [2.56"]

**b Blind hollow shaft**

(insertion depth max. 41.5 mm [1.63"])

- 1 = ø 12 mm [0.47"]
- 2 = ø 14 mm [0.55"]

**c Interface / power supply**

- 2 = SSI, BiSS / 10 ... 30 V DC

**d Type of connection**

- 1 = axial cable, 2 m [6.56'] PUR
- 2 = radial cable, 2 m [6.56'] PUR
- A = axial cable, length > 2 m [6.56']
- B = radial cable, length > 2 m [6.56']

**e Code**

- B = SSI, binary
- C = BiSS, binary
- G = SSI, gray

**f Resolution <sup>2)</sup>**

- A = 10 bit ST + 12 bit MT
- 1 = 11 bit ST + 12 bit MT
- 2 = 12 bit ST + 12 bit MT
- 3 = 13 bit ST + 12 bit MT
- 4 = 14 bit ST + 12 bit MT
- 7 = 17 bit ST + 12 bit MT

**g Inputs / outputs <sup>2)</sup>**

- 2 = SET, DIR input  
additional status output

**h Options**

- 1 = no option

**i Cable length in dm <sup>1)</sup>**

- 0050 = 5 m [16.40']
- 0100 = 10 m [32.81']
- 0150 = 15 m [49.21']
- 0200 = 20 m [65.62']

*Optional on request*

- special cable length
- other singleturn resolutions
- IP65 version for T6
- seawater resistant (stainless steel V4A)

Accessories		Order no.
<b>EMC shield terminal</b>	for top-hat rail mounting	<b>8.0000.4G06.0312</b>
<b>Screw retention</b>	Loctite 243, 5 ml	<b>8.0000.4G05.0000</b>
<b>Bellows coupling, safety-oriented</b>	You will find an overview of our couplings for Sendix shaft encoders in the accessories section or under <a href="http://kuebler.com/accessories">kuebler.com/accessories</a> .	
<b>Safety modules Safety-M compact</b>	You will find an overview of our systems and components for Functional Safety and the corresponding software in the safety technology section or under <a href="http://kuebler.com/safety">kuebler.com/safety</a> .	
<b>LED SSI display 570 / 575</b>	Electronic position display up to 32 bit. You will find an overview in the accessories section or under <a href="http://kuebler.com/position_display">kuebler.com/position_display</a> .	

Further accessories can be found in the accessories section or in the accessories area of our website at: [kuebler.com/accessories](http://kuebler.com/accessories).  
Additional connectors can be found in the connection technology section or in the connection technology area of our website at: [kuebler.com/connection\\_technology](http://kuebler.com/connection_technology).

Technical data		Notes regarding "Functional Safety"	
<b>Explosion protection</b>		<b>Safety characteristics</b>	
<b>ATEX</b>		<b>Classification</b>	PLd / SIL2
<b>EC type-examination certificate</b>	PTB09 ATEX 1106 X	<b>System structure</b>	2 channel (Cat. 3)
<b>Category (gas)</b>	II 2 G Ex d IIC T4 - T6 Gb	<b>PFH<sub>d</sub> value <sup>3)</sup></b>	2.16 x 10 <sup>-8</sup> h <sup>-1</sup>
<b>Category (dust)</b>	II 2D Ex tb IIIC T135°C - T85°C Db	<b>Mission time / Proof test interval</b>	20 years
<b>Relevant standards</b>	EN 60079-0:2012; EN 60079-1:2014; EN 60079-31:2009	<b>Relevant standards</b>	EN ISO 13849-1:2015; EN ISO 13849-2:2012; EN 61800-5-2:2007
<b>IECEX</b>			
<b>Certificate of Conformity (CoC)</b>	IECEX PTB 13.0026 X		
<b>Category (gas)</b>	Ex d IIC T4 - T6 Gb		
<b>Category (dust)</b>	Ex tb IIIC T135°C - T85°C Db		
<b>Relevant standards</b>	IEC 60079-0:2011; IEC 60079-1:2014; IEC 60079-31:2008		

1) Not applicable with connection types 1 and 2.  
2) Resolution, preset value and counting direction factory-programmable.

3) The specified value is based on a diagnostic coverage of 90 %, that must be achieved with an encoder evaluation unit.  
The encoder evaluation unit must meet at least the requirements for SIL2.

# Absolute encoders – multitrurn

<b>Standard, ATEX/IECEX – zone 1/21 SIL2/PLd, mechanical multitrurn, optical</b>	<b>Sendix 7063FS2 / 7083FS2 (shaft / hollow shaft)</b>	<b>SSI/BiSS + SinCos</b>
--	--	--------------------------

Electrical characteristics	
<b>Power supply</b>	10 ... 30 V DC
<b>Current consumption (no load)</b>	max. 50 mA
<b>Reverse polarity protection for power supply</b>	yes
<b>Short circuit proof outputs</b>	yes <sup>1)</sup>
<b>CE compliant acc. to</b>	EMC guideline 2014/30/EU ATEX guideline 2014/34/EU Machinery directive 2006/42/EC RoHS guideline 2011/65/EU

EMC	
<b>Relevant standards</b>	EN 55011 class B:2009 / A1:2010 EN 61326-1:2013 EN 61326-3-1:2008

Mechanical characteristics	
<b>Maximum speed</b>	6000 min <sup>-1</sup> (continuous)
<b>Starting torque – at 20°C [68°F]</b>	< 0.05 Nm
<b>Mass moment of inertia</b>	4.0 x 10 <sup>-6</sup> kgm <sup>2</sup>
<b>Load capacity of shaft</b>	radial 80 N axial 40 N
<b>Weight</b>	approx. 1.3 kg [45.86 oz]
<b>Protection acc. to EN 60529</b>	IP67
<b>Ambient temperature</b>	-40°C ... +60°C [-40 ... +140°F] Please note the specifications for temperature class in EC type-examination certificate!
<b>Material</b>	shaft stainless steel flange / housing seawater durable Al, type AISiMgMn (EN AW-6082) cable PUR
<b>Shock resistance acc. to EN 60068-2-27</b>	500 m/s <sup>2</sup> , 11 ms
<b>Vibration resistance acc. to EN 60068-2-6</b>	200 m/s <sup>2</sup> , 5 ... 2000 Hz

SSI interface	
<b>Output driver</b>	RS485 transceiver type
<b>Permissible load / channel</b>	max. +/- 20 mA
<b>Signal level</b>	HIGH typ 3.8 V LOW at I <sub>Load</sub> = 20 mA typ 1.3 V
<b>Resolution singleturn</b>	10 ... 14 bit and 17 bit
<b>Number of revolutions (multitrurn)</b>	4096 (12 bit)
<b>Code</b>	binary or gray
<b>SSI clock rate</b>	50 kHz ... 2 MHz
<b>Data refresh rate</b>	ST resolution ≤ 14 bit ≤ 1 μs ST resolution ≥ 15 bit 4 μs
<b>Monoflop time</b>	≤ 15 μs
<b>Note:</b> if clock starts cycling within monoflop time a second data transfer starts with the same data. If clock starts cycling after monoflop time, the data transfer starts with updated values. The update rate depends on clock speed, data length and monoflop time.	

BiSS interface	
<b>Output driver</b>	RS485 transceiver type
<b>Permissible load / channel</b>	max. +/- 20 mA
<b>Signal level</b>	HIGH typ 3.8 V LOW at I <sub>Load</sub> = 20 mA typ 1.3 V
<b>Resolution singleturn</b>	10 ... 14 bit and 17 bit
<b>Number of revolutions (multitrurn)</b>	4096 (12 bit)
<b>Code</b>	binary
<b>Clock rate</b>	up to 10 MHz
<b>Max. update rate</b>	< 10 μs, depends on the clock rate and the data length
<b>Data refresh rate</b>	ST resolution ≤ 14 bit ≤ 1 μs ST resolution 17 bit 2.4 μs
<b>Note:</b>	– bidirectional, factory programmable parameters are: resolution, code, direction, alarms and warnings – CRC data verification

SinCos interface	
<b>Max. frequency -3dB</b>	400 kHz
<b>Signal level</b>	1 V <sub>pp</sub> (±10 %)
<b>Short circuit proof</b>	yes <sup>1)</sup>
<b>Pulse rate</b>	2048 ppr

SET input	
<b>Input</b>	HIGH active
<b>Input type</b>	comparator
<b>Signal level (+V = Power supply)</b>	HIGH min. 60 % of +V max. +V LOW max. 25 % of +V
<b>Input current</b>	< 0.5 mA
<b>Min. pulse duration (SET)</b>	10 ms
<b>Timeout after SET signal</b>	14 ms

The encoder can be set to zero at any position by means of a HIGH signal on the SET input. Other preset values can be factory-programmed. The SET input has a signal delay time of approximately 1 ms. Once the SET function has been triggered, the encoder requires an internal processing time of approximately 15 ms before the new position data can be read. If this input is not used, it should be connected to 0 V (Encoder ground GND) in order to avoid interferences.

Power-ON	
After Power-ON the device requires a time of approx. 150 ms before valid data can be read.	
Hot plugging of the encoder should be avoided.	

1) Short circuit to 0 V or to output, one channel at a time, power supply correctly applied.

# Absolute encoders – multiturn

**Standard, ATEX/IECEX – zone 1/21  
SIL2/PLd, mechanical multiturn, optical**

**Sendix 7063FS2 / 7083FS2 (shaft / hollow shaft)**

**SSI/BiSS+SinCos**

## Terminal assignment

Interface	Type of connection	Features	Cable (isolate unused cores individually before initial start-up)												
			Signal:	0 V	+V	C+	C-	D+	D-	SET	A	$\bar{A}$	B	$\bar{B}$	$\perp$
4	1, 2, A, B	SET	Core marking:	6	1	2	3	4	5	11	7	8	9	10	shield

+V: Encoder power supply +V DC

0 V: Encoder power supply ground GND (0 V)

C+, C-: Clock signal

D+, D-: Data signal

SET: SET input

A,  $\bar{A}$ : Cosine signal

B,  $\bar{B}$ : Sine signal

$\perp$ : Protective earth

## Dimensions shaft version

Dimensions in mm [inch]

### Clamping / synchronous flange, $\varnothing$ 70 [2.76]

#### Shaft type 1 with axial cable outlet

- 1 9 x M4, 10 [0.39] deep
- 2 Keyway for DIN 6885-A-4x4x25 key

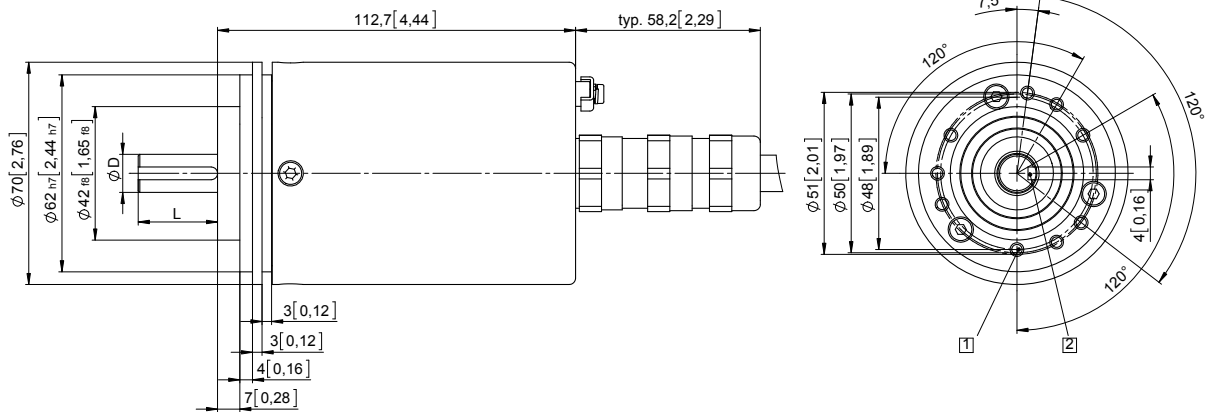

D	Fit	L
12 [0.47]	g6	25 [0.98]

### Clamping / synchronous flange, $\varnothing$ 70 [2.76]

#### Shaft type 2 with radial cable outlet

- 1 9 x M4, 10 [0.39] deep

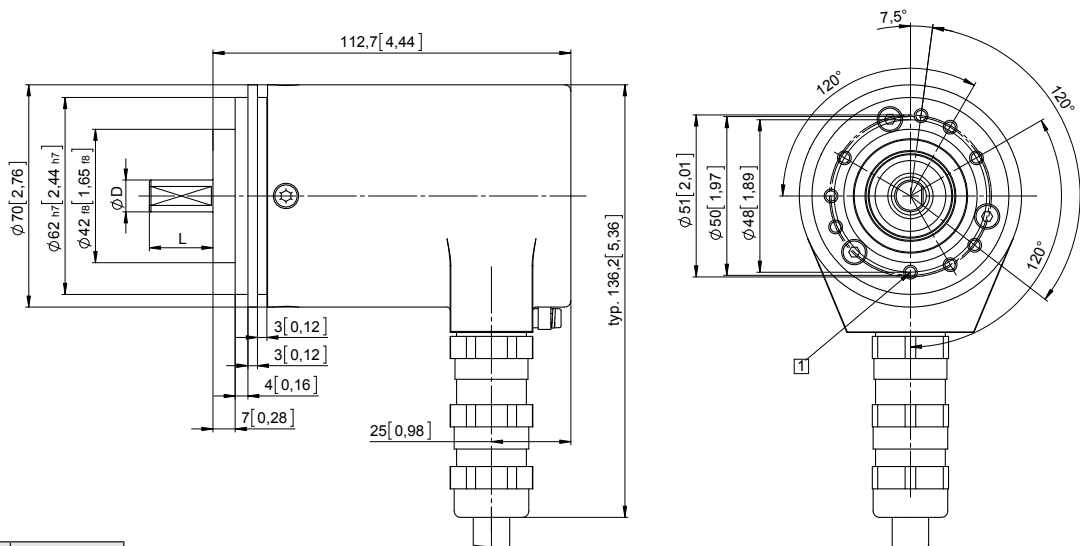

D	Fit	L
10 [0.39]	f7	20 [0.79]

# Absolute encoders – multiturn

<b>Standard, ATEX/IECEx – zone 1/21 SIL2/PLd, mechanical multiturn, optical</b>	<b>Sendix 7063FS2 / 7083FS2 (shaft / hollow shaft)</b>	<b>SSI/BiSS + SinCos</b>
---	--	--------------------------

## Dimensions hollow shaft version

Dimensions in mm [inch]

### Flange with spring element, short Flange type 1

- 1 9 x M4, 10 [0.39] deep
- 2 Slot spring element, recommendation: cylindrical pin DIN 7,  $\varnothing$  4 [0.16]
- 3 Recommended torque for the clamping ring 2.5 Nm

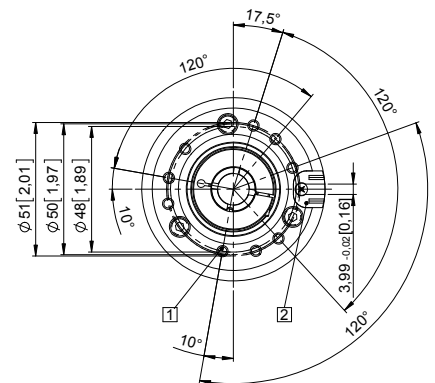
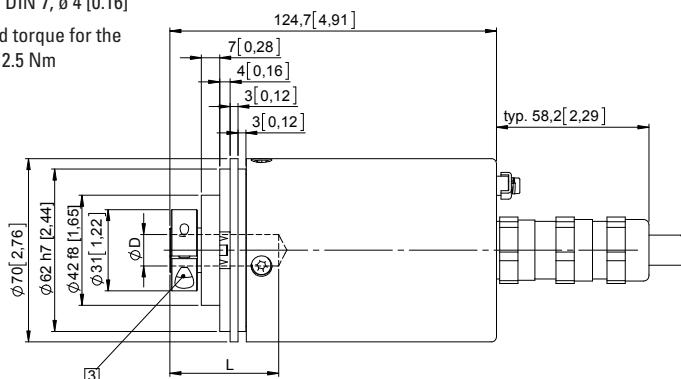

D	Fit	L
12 [0.47]	H7	41.5 [1.63"]
14 [0.55]	H7	41.5 [1.63"]

L = insertion depth max. blind hollow shaft

### Flange with stator coupling, $\varnothing$ 65 [2.56]

#### Flange type 5

- 1 Recommended torque for the clamping ring 2.5 Nm

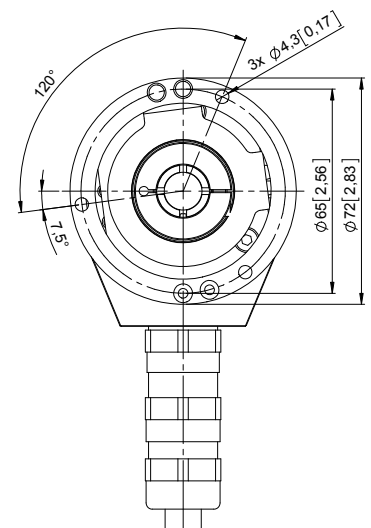
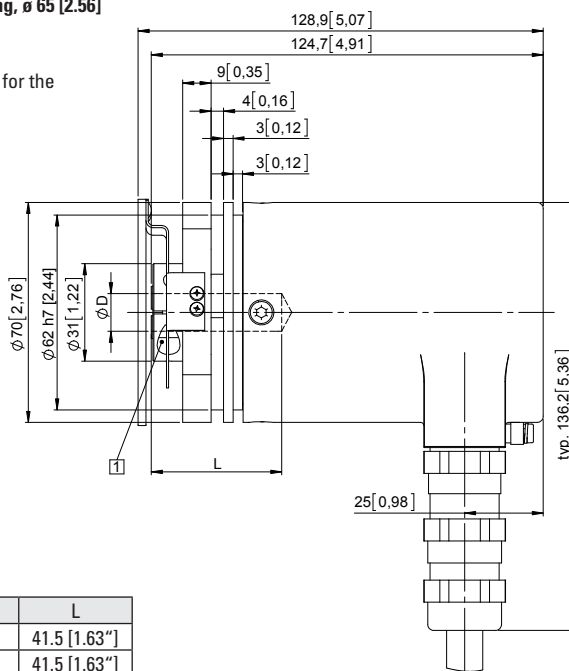

D	Fit	L
12 [0.47]	H7	41.5 [1.63"]
14 [0.55]	H7	41.5 [1.63"]

L = insertion depth max. blind hollow shaft