

BIS U-102-05/CA-HT BIS00WC

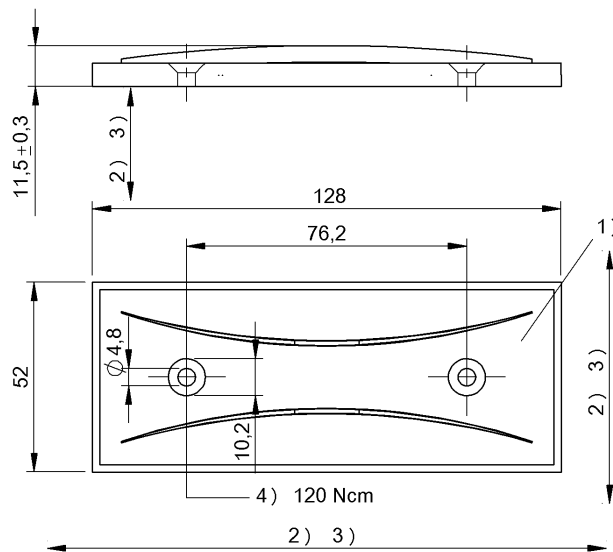

1) Sensing surface 2) Clear zone 3) see corresponding R/W head 4) Tightening torque



Electrical data

Data retention time/years	≥ 50
EN 61000-4-2/3/4/5/6	Severity. Level 4B / 3A / - / - / -
Memory capacity	240 Bit EPC
Memory size, read	64 Bit TID
Polarization	linear
Preferred application	860...960 MHz
Programming cycles	up to 55 °C: 100,000
Read cycles	Unlimited

Environmental conditions

Ambient temperature	-40...85 °C
EN 60068-2-27, Continuous shock load	yes
EN 60068-2-27, Shock	yes
EN 60068-2-6, Vibration	yes
Protection type IEC 60529	IP68
Storage temperature	-40...220 °C

Functional safety

EN 60068-2-32 Free fall	yes
-------------------------	-----

General data

Approval/Conformity	CE
EN 55022	Size 1, Cl. B
Standards	EPCglobal™ Class 1, Gen 2 ISO 18000-6C
User data	512 Bit

Material

Housing material	PPS
------------------	-----

Mechanical data

Application weight	70.00 g
Dimension	52 x 11.5 x 128 mm

Remarks

Use spacers to fasten the data carrier to flat metal surfaces.
Storage temperature 1000 h or 1500 cycles à 30 min.
For installation in metal: Observe clear zone.
Values are under rated conditions unless otherwise specified.
Time specification includes data check.
For installation requirements see corresponding read/write head.
Only when used together with the appropriate read/write head.