

## 凸輪開關

BNS 819-D03-D12-100-10-FD-S4L-I

訂購代碼: BNS04H2

# BALLUFF

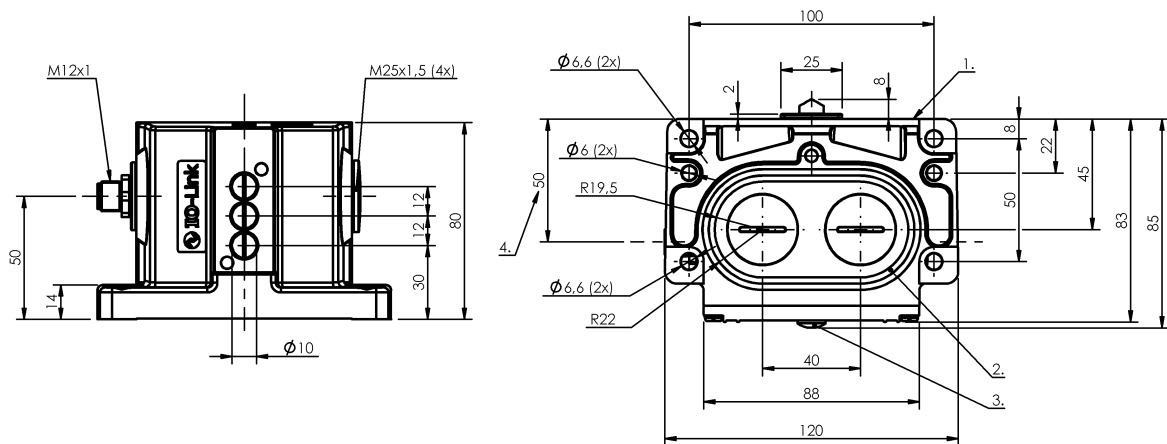

1) 參考沿, 2) 密封環, 3) 功能顯示 FD/FE/LL, 4) 電纜通道



### Basic features

DIN 開關	DIN 43697
作用原理	1-3. 開關位置: 機械
基本標準	IEC 60947-5-1
規格	突動觸點
認證	CE UKCA WEEE

### Display/Operation

功能顯示	1-3. 開關位置: LED
------	----------------

### Electrical connection

接口	M12x1 法蘭插頭, 4 針, A 編碼
連接方式	1. 開關位置: 插接器

### Electrical data

測量工作電壓 Ue DC	24 V
開關功能, 機械	雙重斷路 電隔離 一個常開觸點和一個常閉觸點 二回路轉換觸點

開關頻率	1-3. 開關位置: 300/min
------	--------------------

### Environmental conditions

環境溫度	-5...85 °C
防護等級	IP67

### Functional safety

B10d (EN ISO 13849-1)	BSE 30.0 : 3 千萬電路循環
-----------------------	---------------------

### Interface

介面	IO-Link 1.1
循環時間, 最小	3 ms
框架類型	2.1
程序數據週期, 最小	3 ms

### Material

外殼材質	鋁, 陽極化
摺桿材料	1-3. 開關位置: 不鏽鋼 (1.4034)
表面保護, 外殼材料	陽極化
觸點材料	1-3. 開關位置: 純銀, 鍍金

### Mechanical data

Number of switching positions	3x 頂部 機械
使用壽命, 機械	1-3. 開關位置: 3 千萬次開關
凸輪至基準線的距離	1-3. 開關位置: 4.50...5.00 mm
安裝	垂直
摺桿形狀	第 1 - 第 3 開關位置: 頂部 第 1 - 第 3 開關位置: 頂部
法蘭, 套管	2x 螺紋輸出端 M25
起步方向	縱向、平行於旋接面
起步速度	1-3. 開關位置: 40 m/min
開關元件	1-3. 開關位置: BSE 30.0
開關操作力	1-3. 開關位置: 20 N

凸輪開關  
BNS 819-D03-D12-100-10-FD-S4L-I  
訂購代碼: BNS04H2

# BALLUFF

Range/Distance

重複性

1-3. 開關位置:  $\pm 0.002$  mm

## Connector Drawings

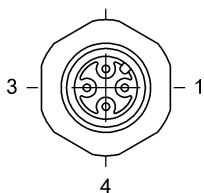

插頭側視圖

## Wiring Diagrams (Schematic)

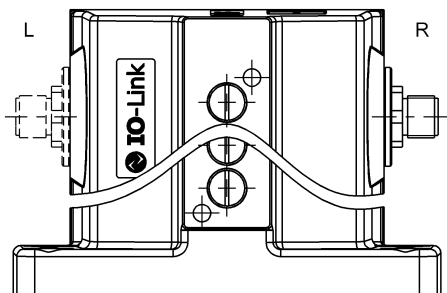

PIN 1: +24V  
PIN 3: 0V  
PIN 4: IO-Link



Help Views

**BNS with IO-Link from 1 up to 16 positions**

Frame type: 2.1

Process data length: 1 Byte

**Process data image:**

Process data: ≤ 8 positions															
Byte 0															
7	6	5	4	3	2	1	0	7	6	5	4	3	2	1	0
NO / NC 8	NO / NC 7	NO / NC 6	NO / NC 5	NO / NC 4	NO / NC 3	NO / NC 2	NO / NC 1	NO / NC 16	NO / NC 15	NO / NC 14	NO / NC 13	NO / NC 12	NO / NC 11	NO / NC 10	NO / NC 9
Process data: > 8 positions															
Byte 0								Byte 1							
7	6	5	4	3	2	1	0	7	6	5	4	3	2	1	0
NO / NC 8	NO / NC 7	NO / NC 6	NO / NC 5	NO / NC 4	NO / NC 3	NO / NC 2	NO / NC 1	NO / NC 16	NO / NC 15	NO / NC 14	NO / NC 13	NO / NC 12	NO / NC 11	NO / NC 10	NO / NC 9

**On-request data:**

	DPP		SPDU		Object name	Length	Range	Default value
	Index	Index	Index	Sub-Index				
Identification Data	0x07				Vendor ID	2 Byte	read only	0x0378
	0x08				Decice ID	3 Byte		0x01010X X = No. of positions
	0x09							
	0x0A							BALLUFF
	0x0B							www.balluff.com
		0x10	0		Vendor name	7 Byte		BNS 819-xxx-xxx-xx-S4x-l
		0x11	0		Vendor text	15 Byte		BNSxxxx
		0x12	0		Product name	31 Byte		BNS xx-fach
		0x13	0		Product ID	7 Byte		
		0x14	0		Product text	10 / 11 Byte		
Programmable Data			0x40	0	NO / NC	≤ 8 positions = 1 Byte	0x00 - (2^positions)-1 (1 Bit = 1 position)	"0"
						> 8 positions = 2 Byte		
			1 - 16			1 Byte		

**Errors:**

Class			Error Code		Additional Code	
Mode	Type	Instance				
single shot	Error	AL	Device application error		Index not available	
0x40	0x30	0x03	0x80		0x11	
			0x73		0x11	
single shot	Error	AL	Device application error		Sub-Index not available	
0x40	0x30	0x03	0x80		0x12	
			0x73		0x12	

**Input data: No input data available**