

Bearingless encoders

Incremental, programmable magnetic	RIM2000 / RIM5000 (hollow shaft)	Push-pull / RS422
---	---	--------------------------



Maximum flexibility and higher performance thanks to programmability.

With a new technology approach based on digital signal processing independent of previous ASIC solutions, Kübler has expanded the range of applications for bearingless encoders. In conjunction with the available magnetic rings, the best possible accuracy is now always achieved. Influences due to individual installation and temperature differences during operation are automatically compensated in the sensor head. This facilitates integration into applications and makes the overall system even more powerful.

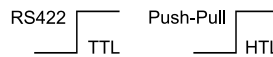

Features and benefits

- **Maximum flexibility thanks to programmability**
 - Programmable via programming device with touch display.
 - Freely selectable resolution up to 999 999 ppr independent of the magnetic ring diameter.
 - Systems based on both, 2 mm and 5 mm, pole lengths are available. This allows you to choose between larger operating and mounting tolerances or a focus on the best possible performance.
 - Many variants of magnetic ring and bore diameters.
- **Highest precision**
Active offset, phase and amplitude control automatically optimizes the sensor to the current operating situation. Influences due to individual installation and temperature differences during operation are automatically compensated in the sensor head.
- **Fast and easy implementation**
 - For use in small installation spaces.
 - Mounting tolerance between magnetic ring and sensor head are compensated by the electronics.
 - Simple adjustment by fastening via slotted holes.
 - Function display via LED.
- **Resistant and robust**
 - Non-contact and wear-free measuring system for a long service life.
 - High shock and vibration resistance.
 - Sturdy housing with degree of protection IP67, optional: Special housing for high resistance to condensation (IP68 / IP69, Resistance to cyclical humidity acc. to EN 60068-2-38 and humidity-heat acc. to EN 60068-2-78).

Selection of sensor head

RIM2000

The RIM2000 system with 2 mm pole length should be used for high signal quality requirements. This requires good bearings and a stable installation process that allows an air gap of up to 1 mm.



RIM5000

If the application requires a larger air gap (up to max. 2 mm), the RIM5000 system with 5 mm pole length is used. High performance is also offered here with equally high signal quality..

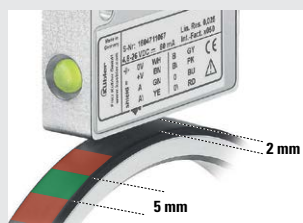

Selection of magnetic ring

Outer diameter

Even if a high resolution can be realized for all outer diameters, it is recommended to select the largest possible diameter.



Bore hole

Various diameters and fastening types are available for mounting on the application shaft.



Bearingless encoders

Incremental, programmable magnetic

RIM2000 / RIM5000 (hollow shaft)

Push-pull / RS422

Order code RIM2000

Pole length 2 mm / distance between sensor head and magnetic ring max. 1 mm

8.RIM2000 . **X** **X** **X** **X** **A** . **XXX** . **XXXXX** . **XXXXXX** . **XXXX**

Combination sensor head LI2000 + magnetic ring RI20 (can also be ordered separately)

a *Mounting type*

- 1 = Hub screw
- 2 = Press fit

b *Model*

- 1 = IP67, standard
- 2 = IP68 / IP69 and humidity tested acc. to EN 60068-2-38, EN 60068-2-78

c *Zero pulse magnetic ring¹⁾*

- 1 = without zero pulse
- 2 = with zero pulse

d *Output circuit / Supply voltage*

- 1 = RS422 / 4.8 ... 26.4 V DC
- 2 = Push-pull (HTL/TTL universal) / 4.8 ... 26.4 V DC

e *Type of connection*

- A = radial cable, PUR (cable length see **f**)

f *Outer diameter magnetic ring*

see table

g *Bore diameter magnetic ring*

see table

h *Pulses per revolution*

- 1 ... 999999 (e.g. 001024 for 1024 ppr)

i *Cable length (XXXX = length in dm)*

- 0020 = 2 m [6.56'] (standard)
- 0030 = 3 m [9.84']
- 0050 = 5 m [16.40']
- 0080 = 8 m [26.25'] (only with supply voltage > 6 V)
- 0100 = 10 m [32.80'] (only with supply voltage > 6 V)
- 0150 = 15 m [49.21'] (only with supply voltage > 6 V)
- 0200 = 20 m [65.62'] (only with supply voltage > 6 V)

Magnetic ring with hub screw, pole length 2 mm (for mounting type **a** = 1)

Outer diameter [mm] ±0.10	Width [mm] ±0.30	Number of poles	Order code c zero pulse ¹⁾	Material hub	Order code f outer diameter	ø Bore [mm]	Order code g bore	max. speed min ⁻¹	Magnet material
31	16	50	1 (no)	Aluminum	031	8 H7	00800	12.000	Ferrite
						10 H7	01000		
						12 H7	01200		
						15 H7	01500		
						15.875 H7	01587		
						18 H7	01800		
41.2	16	64	1 (no)	Aluminum	041	8 H7	00800	12.000	Ferrite
						10 H7	01000		
						12 H7	01200		
						15 H7	01500		
						18 H7	01800		
						20 H7	02000		
40.74	16	64	2 (yes)	Stainless steel	041	8 H7	00800	12.000	Ferrite
						20 H7	02000		
						25 H7	02500		
45	16	72	1 (no)	Aluminum	045	8 H7	00800	12.000	Ferrite
						9.25 H7	00925		
						10 H7	01000		
						12 H7	01200		
						15 H7	01500		
						18 H7	01800		
						20 H7	02000		
						25 H7	02500		
						25.4 H7	02540		
						28.575 H7	02857		
30 H7	03000								

Magnetic ring press fit, pole length 2 mm (for mounting type **a** = 2)

48.90	10.40	80	2 (yes)	Steel	049	45.4 ±0.05	04540	15.000	Vulcanized rubber
87.13	9	140	1 (no)	Stainless steel	087	76 H7	07600	12.000	
202.3	9	320	1 (no)	Stainless steel	202	180 ±0.10	18000	2.000	

1) The sensor head always includes the function of evaluating a zero pulse.

Whether the RIMxxx system provides a zero pulse as an output signal depends on the choice of magnetic ring (with zero pulse **c** = 2 or without zero pulse **c** = 1). For magnetic rings with a zero pulse, this is detected once per revolution. For full-track magnetic rings without zero pulse, a signal is detected for every second pole.

Bearingless encoders

Incremental, programmable magnetic	RIM2000 / RIM5000 (hollow shaft)	Push-pull / RS422
---	---	--------------------------

Order code RIM5000	8.RIM5000	X	X	X	X	A	.	XXX	.	XXXXX	.	XXXXXX	.	XXXX
Pole length 5 mm / distance between sensor head and magnetic ring max. 2 mm	Type	a	b	c	d	e	f	g	h	i	Combination sensor head LI2000 + magnetic ring RI20 (can also be ordered separately)			

<p>a <i>Mounting type</i></p> <p>1 = Hub screw 2 = Press fit</p> <p>b <i>Model</i></p> <p>1 = IP67, standard 2 = IP68 / IP69 and humidity tested acc. to EN 60068-2-38, EN 60068-2-78</p> <p>c <i>Zero pulse magnetic ring¹⁾</i></p> <p>1 = without zero pulse 2 = with zero pulse</p> <p>d <i>Output circuit/ Supply voltage</i></p> <p>1 = RS422 / 4.8 ... 26.4 V DC 2 = Push-pull (HTL/TTL universal) / 4.8 ... 26.4 V DC</p> <p>e <i>Type of connection</i></p> <p>A = radial cable, PUR (cable length see i)</p>	<p>f <i>Outer diameter magnetic ring</i></p> <p>see table</p> <p>g <i>Bore diameter magnetic ring</i></p> <p>see table</p> <p>h <i>Pulses per revolution</i></p> <p>1 ... 999999 (e.g. 001024 for 1024 ppr)</p> <p>i <i>Cable length (XXXX = length in dm)</i></p> <p>0020 = 2 m [6.56'] (standard) 0030 = 3 m [9.84'] 0050 = 5 m [16.40'] 0080 = 8 m [26.25'] (only with supply voltage > 6 V) 0100 = 10 m [32.80'] (only with supply voltage > 6 V) 0150 = 15 m [49.21'] (only with supply voltage > 6 V) 0200 = 20 m [65.62'] (only with supply voltage > 6 V)</p>
--	---

Magnetic ring with hub screw, pole length 5 mm (for mounting type **a = 1)**

Outer diameter [mm] ±0.10	width [mm] ±0.30	number of poles	Order code c zero pulse ¹⁾	material hub	order code f outer diameter	ø bore [mm]	order code g bore	max. speed min ⁻¹	magnet material
31	16	20	2 (yes)	Stainless steel	031	6 H7	00600	12.000	Ferrite
						8 H7	00800		
						10 H7	01000		
						12 H7	01200		
						15 H7	01500		
						20 H7	02000		
48.3	16	32	2 (yes)	Stainless steel	048	6 H7	00600	12.000	Ferrite
						8 H7	00800		
						10 H7	01000		
						12 H7	01200		
						15 H7	01500		
						20 H7	02000		
						25 H7	02500		
						25.4 H7	02540		
28 H7	02800								
						30 H7	03000		
50.11	16	32	2 (yes)	Stainless steel	050	20 H7	02000	12.000	Vulcan. rubber
54.70	16	36	2 (yes)	Stainless steel	055	6 H7	00600	12.000	Ferrite
						8 H7	00800		
						10 H7	01000		
						12 H7	01200		
						15 H7	01500		
						20 H7	02000		
						25 H7	02500		
						30 H7	03000		
						35 H7	03500		
102	20	64	1 (no)	Stainless steel	102	70 H7	07000	4.000	Bonded rubber
			2 (yes)	Stainless steel	102	70 H7	07000		

Magnetic ring press fit, pole length 5 mm (for mounting type **a = 2)**

48.90	10.40	32	2 (yes)	Steel	049	45.4 ±0.05	04540	15.000	Vulcan. rubber
202.3	9	128	1 (no)	Stainless steel	202	180 ±0.10	18000	2.000	Vulcanized rubber
			2 (yes)	Stainless steel	202	180 ±0.10	18000		

1) The sensor head always includes the function of evaluating a zero pulse.
Whether the RIMxxx system provides a zero pulse as an output signal depends on the choice of magnetic ring (with zero pulse **c** = 2 or without zero pulse **c** = 1).
For magnetic rings with a zero pulse, this is detected once per revolution. For full-track magnetic rings without zero pulse, a signal is detected for every second pole.

Bearingless encoders

Incremental, programmable magnetic	RIM2000 / RIM5000 (hollow shaft)	Push-pull / RS422
---	---	--------------------------

Order code sensor head LI2000 Pole length 2 mm / distance between sensor head and magnetic ring max. 1 mm suitable magnetic rings see below	<table border="1" style="border-collapse: collapse; margin: auto;"> <tr> <td style="padding: 2px 5px;">8.LI2000</td> <td style="padding: 2px 5px;">.</td> <td style="padding: 2px 5px;">X</td> <td style="padding: 2px 5px;">2</td> <td style="padding: 2px 5px;">X</td> <td style="padding: 2px 5px;">A</td> <td style="padding: 2px 5px;">.</td> <td style="padding: 2px 5px;">XXX</td> <td style="padding: 2px 5px;">.</td> <td style="padding: 2px 5px;">XXXXXX</td> <td style="padding: 2px 5px;">.</td> <td style="padding: 2px 5px;">XXXX</td> </tr> <tr> <td style="font-size: small;">Typ</td> <td></td> <td style="font-size: x-small;">b</td> <td style="font-size: x-small;">c</td> <td style="font-size: x-small;">d</td> <td style="font-size: x-small;">e</td> <td></td> <td style="font-size: x-small;">k</td> <td></td> <td style="font-size: x-small;">h</td> <td></td> <td style="font-size: x-small;">i</td> </tr> </table>	8.LI2000	.	X	2	X	A	.	XXX	.	XXXXXX	.	XXXX	Typ		b	c	d	e		k		h		i
8.LI2000	.	X	2	X	A	.	XXX	.	XXXXXX	.	XXXX														
Typ		b	c	d	e		k		h		i														
b Model 1 = IP67, standard 2 = IP68 / IP69 and humidity tested acc. to EN 60068-2-38, EN 60068-2-78	k Input periods Number of magnetic poles, depending on the magnetic ring (e.g. 72 magnetic poles = 072)																								
c Zero Pulse 2 = with zero pulse evaluation ¹⁾	h Pulses per revolution 1 ... 999999 (e.g. 001024 for 1024 ppr)																								
d Output circuit / Supply voltage 1 = RS422 / 4.8 ... 26.4 V DC 2 = Push-pull (HTL/TTL universal) / 4.8 ... 26.4 V DC	i Cable length (XXXX = length in dm) 0020 = 2 m [6.56'] (standard) 0030 = 3 m [9.84'] 0050 = 5 m [16.40'] 0080 = 8 m [26.25'] (only with supply voltage > 6 V) 0100 = 10 m [32.80'] (only with supply voltage > 6 V) 0150 = 15 m [49.21'] (only with supply voltage > 6 V) 0200 = 20 m [65.62'] (only with supply voltage > 6 V)																								
e Type of connection A = radial cable, PUR (cable length see i)																									

Magnetic ring with hub screw, pole length 2 mm – suitable for sensor head LI2000

outer diameter [mm] ±0.10	width [mm] ±0.30	number of poles	zero pulse ¹⁾	material hub	ø bore [mm]	order code	max. speed min ⁻¹	magnet material
31	16	50	no	Aluminum	8 H7	8.RI20.031.0800.111	12.000	Ferrite
					10 H7	8.RI20.031.1000.111		
					12 H7	8.RI20.031.1200.111		
					15 H7	8.RI20.031.1500.111		
					15.875 H7	8.RI20.031.1587.111		
					18 H7	8.RI20.031.1800.111		
20 H7	8.RI20.031.2000.111							
41.2	16	64	no	Aluminum	8 H7	8.RI20.041.0800.111	12.000	Ferrite
					10 H7	8.RI20.041.1000.111		
					12 H7	8.RI20.041.1200.111		
					15 H7	8.RI20.041.1500.111		
					18 H7	8.RI20.041.1800.111		
20 H7	8.RI20.041.2000.111							
40.74	16	64	yes	Stainless steel	8 H7	8.RI20.041.0800.112	12.000	Ferrite
					20 H7	8.RI20.041.2000.112		
					25 H7	8.RI20.041.2500.112		
45	16	72	no	Aluminum	8 H7	8.RI20.045.0800.111	12.000	Ferrite
					9.25 H7	8.RI20.045.0925.111		
					10 H7	8.RI20.045.1000.111		
					12 H7	8.RI20.045.1200.111		
					15 H7	8.RI20.045.1500.111		
					18 H7	8.RI20.045.1800.111		
					20 H7	8.RI20.045.2000.111		
					25 H7	8.RI20.045.2500.111		
					25.4 H7	8.RI20.045.2540.111		
					28.575 H7	8.RI20.045.2857.111		
30 H7	8.RI20.045.3000.111							

Magnetic ring press fit, pole length 2 mm – suitable for sensor head LI2000

48.90	10.40	80	yes	Steel	45.4 ±0.05	8.RI20.049.4540.242	15.000	Vulcanized rubber
87.13	9	140	no	Stainless steel	76 H7	8.RI20.087.7600.241	12.000	
202.3	9	320	no	Stainless steel	180 ±0.10	8.RI20.202.1800.241	2.000	

¹⁾ The sensor head always includes the function of evaluating a zero pulse (c = 2).
 Whether the RIMxxx system provides a zero pulse as an output signal depends on the choice of magnetic ring (with or without zero pulse).
 For magnetic rings with a zero pulse, this is detected once per revolution. For full-track magnetic rings without zero pulse, a signal is detected for every second pole.

Bearingless encoders

Incremental, programmable magnetic	RIM2000 / RIM5000 (hollow shaft)	Push-pull / RS422
---	---	--------------------------

Order code sensor head LI5000 Pole length 5 mm / distance between sensor head and magnetic ring max. 2 mm suitable magnetic rings see below	<table border="1" style="width: 100%; text-align: center;"> <tr> <td style="font-size: 1.2em;">8.LI5000</td> <td style="font-size: 1.2em;">. X 2 X A .</td> <td style="font-size: 1.2em;">XXX .</td> <td style="font-size: 1.2em;">XXXXXX .</td> <td style="font-size: 1.2em;">XXXX</td> </tr> <tr> <td style="font-size: 0.8em;">Typ</td> <td style="font-size: 0.8em;">b c d e</td> <td style="font-size: 0.8em;">k</td> <td style="font-size: 0.8em;">h</td> <td style="font-size: 0.8em;">i</td> </tr> </table>	8.LI5000	. X 2 X A .	XXX .	XXXXXX .	XXXX	Typ	b c d e	k	h	i
8.LI5000	. X 2 X A .	XXX .	XXXXXX .	XXXX							
Typ	b c d e	k	h	i							

<p>b Model 1 = IP67, standard 2 = IP68 / IP69 and humidity tested acc. to EN 60068-2-38, EN 60068-2-78</p> <p>c Zero Pulse 2 = with zero pulse evaluation ¹⁾</p> <p>d Output circuit/ Supply voltage 1 = RS422 / 4.8 ... 26.4 V DC 2 = Push-pull (HTL/TTL universal) / 4.8 ... 26.4 V DC</p> <p>e Type of connection A = radial cable, PUR (cable length see i)</p>	<p>k Input periods Number of magnetic poles, depending on the magnetic ring (e.g. 32 magnetic poles = 032)</p> <p>h Pulses per revolution 1 ... 999999 (e.g. 001024 for 1024 ppr)</p> <p>i Cable length (XXXX = length in dm) 0020 = 2 m [6.56'] (standard) 0030 = 3 m [9.84'] 0050 = 5 m [16.40'] 0080 = 8 m [26.25'] (only with supply voltage > 6 V) 0100 = 10 m [32.80'] (only with supply voltage > 6 V) 0150 = 15 m [49.21'] (only with supply voltage > 6 V) 0200 = 20 m [65.62'] (only with supply voltage > 6 V)</p>
---	--

Magnetic ring with hub screw, pole length 5 mm – suitable for sensor head LI5000



outer diameter [mm] ±0.10	width [mm] ±0.30	number of poles	zero pulse ¹⁾	material hub	ø bore [mm]	order code	max. speed min ⁻¹	magnet material
31	16	20	yes	Stainless steel	6 H7	8.RI50.031.0600.112	12.000	Ferrite
					8 H7	8.RI50.031.0800.112		
					10 H7	8.RI50.031.1000.112		
					12 H7	8.RI50.031.1200.112		
					15 H7	8.RI50.031.1500.112		
					20 H7	8.RI50.031.2000.112		
48.3	16	32	yes	Stainless steel	6	8.RI50.048.0600.112	12.000	Ferrite
					8 H7	8.RI50.048.0800.112		
					10 H7	8.RI50.048.1000.112		
					12 H7	8.RI50.048.1200.112		
					15 H7	8.RI50.048.1500.112		
					20 H7	8.RI50.048.2000.112		
					25 H7	8.RI50.048.2500.112		
					25.4 H7	8.RI50.048.2540.112		
					28 H7	8.RI50.048.2800.112		
					30 H7	8.RI50.048.3000.112		
50.11	16	32	yes	Stainless steel	20 H7	8.RI50.050.2000.142	12.000	Vulcan. rubber
54.70	16	36	yes	Stainless steel	6 H7	8.RI50.055.0600.112	12.000	Ferrite
					8 H7	8.RI50.055.0800.112		
					10 H7	8.RI50.055.1000.112		
					12 H7	8.RI50.055.1200.112		
					15 H7	8.RI50.055.1500.112		
					20 H7	8.RI50.055.2000.112		
					25 H7	8.RI50.055.2500.112		
					30 H7	8.RI50.055.3000.112		
					35 H7	8.RI50.055.3500.112		
102	20	64	no	Stainless steel	70 H7	8.RI50.102.0700.121	4.000	Bonded rubber
			yes	Stainless steel	70 H7	8.RI50.102.0700.122		

Magnetic ring press fit, pole length 5 mm – suitable for sensor head LI5000

48.90	10.40	32	yes	Steel	45.4 ±0.05	8.RI50.049.4540.242	15.000	Vulcanized rubber
202.3	9	128	no	Stainless steel	180 ±0.10	8.RI50.202.180M.241	2.000	
			yes	Stainless steel	180 ±0.10	8.RI50.202.180M.242	2.000	

1) The sensor head always includes the function of evaluating a zero pulse (c = 2).
Whether the RIMxxx system provides a zero pulse as an output signal depends on the choice of magnetic ring (with or without zero pulse).
For magnetic rings with a zero pulse, this is detected once per revolution. For full-track magnetic rings without zero pulse, a signal is detected for every second pole.

Bearingless encoders

Incremental, programmable magnetic		RIM2000 / RIM5000 (hollow shaft)	Push-pull / RS422
Programming units			Order no.
Programming unit with touch display EP1000 	Programming unit for PC-independent use, even in the field 136 x 84 x 38 mm		8.0010.9000.1000
Accessories / Displays			Order no.
Codix 560, preset counter 6-digit 	<ul style="list-style-type: none"> - Counter, tachometer, time counter and position display in one device - Scalable display - Readable via RS232/485 interface or configurable via MODBUS or CR/LF protocol 		6.560.010.XXX
571T Touch, multifunction preset counters 8-digit 	<ul style="list-style-type: none"> - Measuring function for RPM, speed, speed from elapsed time, machine cycle time, throughput time (reciprocal rotary speed), as well as numerous count functions such as position display - Fast counting input (250 kHz/HTL, 1 MHz/RS422) - 4 switching outputs as limit values (response time < 1 ms) - Scalable analog output (response time < 150 ms), resolution 16 bit - Serial interface RS232 or RS485 for reading in and out the data 		6.571T.01X.XXX

Further Kübler accessories can be found at: kuebler.com/accessories
 Further Kübler cables and connectors can be found at: kuebler.com/connection-technology

Bearingless encoders

Incremental, programmable magnetic	RIM2000 / RIM5000 (hollow shaft)	Push-pull / RS422
---	---	--------------------------

Technical data

Mechanical characteristics	
Maximum speed	12000 min ⁻¹
Protection	Model 1 IP67 acc. to EN 60529 Model 2 IP68 / IP69 acc. to EN 60529 and humidity tested acc. to EN 60068-2-38, EN 60068-2-78
Operating temperature	-20 °C ... +80 °C [-4 °F ... +176 °F]
Shock resistance	5000 m/s ² , 1 ms
Vibration resistance	300 m/s ² , 10 ... 2000 Hz
Pole length	2 mm or 5 mm from pole to pole
Housing (sensor head)	aluminum
Cable	2 m [6.56'] long, PUR 8 x 0.14 mm ² [AWG 26], shielded, may be used in trailing cable installations
Status LED	green ready for operation red Magnetic field error, e.g: - Distance between sensor head and magnetic ring too large - Pole length of magnetic ring and sensor head do not match

Electrical characteristics			
Output circuit	RS422		Push-pull
Supply voltage	4.8 ... 26.4 VDC		4.8 ... 26.4 VDC
Power consumption (no load)	max. 80 mA		max. 80 mA
Permissible load / channel	120 Ohm		+/- 20 mA
Output frequency max.	300 kHz		100 kHz 300 kHz (for supply voltage ≤ 8 V)
Signal level	HIGH	min. 2.5 V	min. +V - 2.0 V
	LOW	max. 0.5 V	max. 0.5 V
Zero pulse	For magnetic rings with zero pulse, once per revolution. For full-track magnetic rings without zero pulse, every two poles.		
System accuracy	typ. 0.3° with shaft tolerance g6		

Approvals			
CE compliant in accordance with			
	EMC Directive	2014/30/EU	
	RoHS Directive	2011/65/EU	

Terminal assignment

Output circuit	Type of connection	Cable (insulate unused cores individually before initial start-up)									
1, 2	A	Signal:	0 V	+V	A	\bar{A}	B	\bar{B}	0	$\bar{0}$	\perp
		Aderfarbe:	WH	BN	GN	YE	GY	PK	BU	RD	shield ¹⁾

- +V: Supply voltage sensor +V DC
- 0 V: Supply voltage sensor ground GND (0 V)
- A, \bar{A} : Incremental output channel A / cosine signal
- B, \bar{B} : Incremental output channel B / sine signal
- 0, $\bar{0}$: Reference signal
- \perp : Sensor housing (shield)

1) Shield is connected to sensor housing.

Bearingless encoders

Incremental, programmable magnetic

RIM2000 / RIM5000 (hollow shaft)

Push-pull / RS422

Mounting orientation and permissible mounting tolerances

Distances

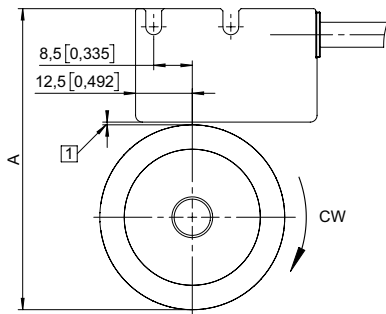

Torsion

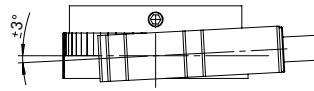

Offset

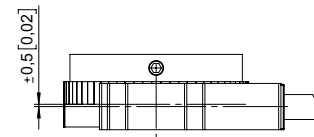

Tilting

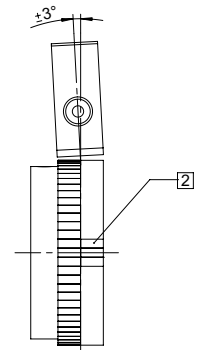

- 1 Distance sensor head / magnetic ring:
 RIM2000: 0.1 ... 1.0 mm (0.4 mm [0.016] recommended)
 RIM5000: 0.1 ... 2.0 mm (1.0 mm [0.039] recommended)

Warning: When mounting the sensor head, please ensure its correct orientation to the magnetic ring (with reference signal)!

- 2 Reference signal

A Depending on the magnetic ring used

Signal figures

A vor B, when turning clockwise (cw)

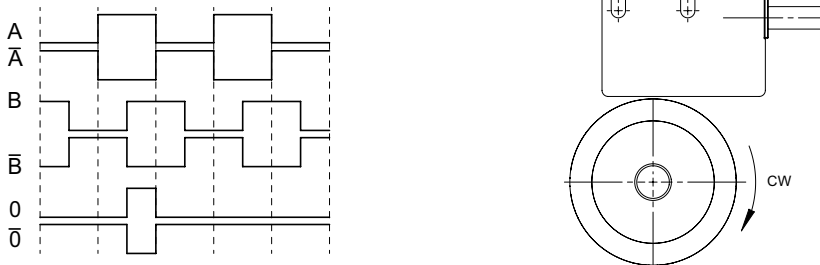

Dimensions

Dimensions in mm [inch]

Sensor head

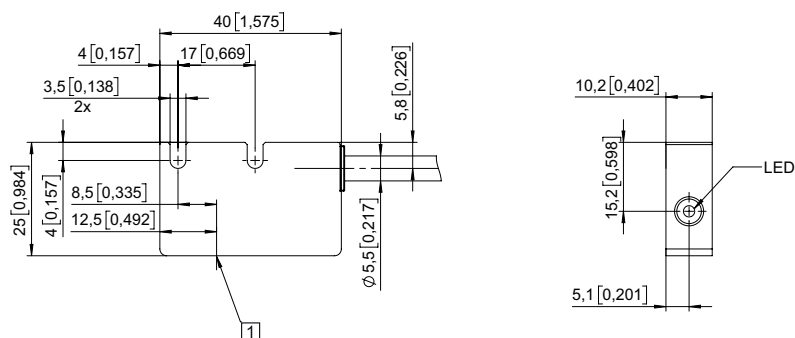

- 1 Active measuring area

Bearingless encoders

Incremental, programmable magnetic	RIM2000 / RIM5000 (hollow shaft)	Push-pull / RS422
---	---	--------------------------

Dimensions

Dimensions in mm [inch]

Magnetic ring with hub screw, outer diameter 31 mm [1.22] up to 54.7 mm [2.15]

ø A [mm] ±0.10	ø B Bore [mm]													C [mm] ø Hub		
	6	8	9.25	10	12	15	15.875	18	20	25	25.4	28.575	28		30	35
31	•	•														28 / 29
40.74		•														28
41.2		•		•	•											28
45		•	•	•	•	•										38
48.3	•	•		•	•	•								•	•	46
50.11															•	40
54.7	•	•			•	•									•	53

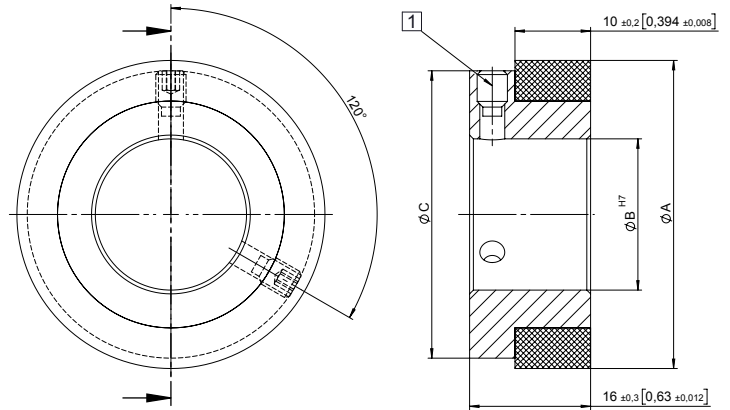

1 Set screw M4

Recommended tolerance of the drive shaft diameter: g6

Magnetic ring with hub screw, outer diameter 102 mm [4.02]

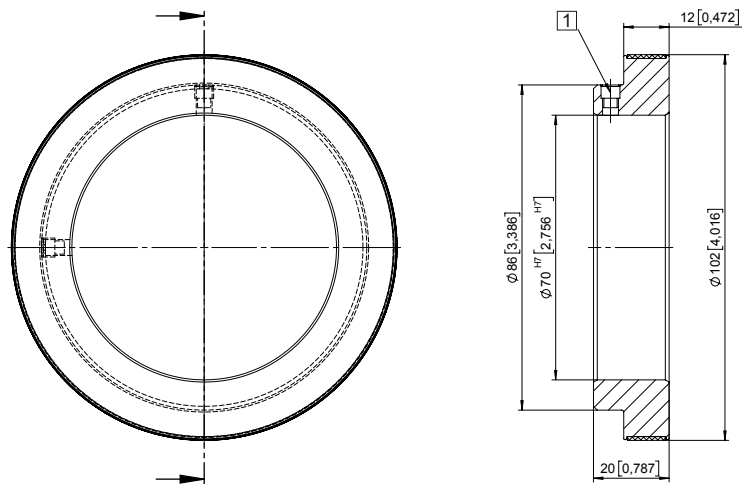

1 Set screw M5

Magnetic ring (press fit)

ø A [mm] ±0.10 Outer diameter	ø B [mm] Bore	C [mm] ±0.30 Width	ø D [mm] Customer shaft + recommended tolerance
48.90	45.4 ±0.05	10.40	45.50 m6
87.13	76 H7	9	76 r6
202.30	180 ±0.10	9	180.18 ±0.03

